

(D) Ersatzteilliste	Motorsäge	656SP	Inhaltsverzeichnis	Seite
			Motoreinheit: Kurbelwelle, Zylinder, Zündung	2
			Auspuff, Vergaser, Luftfilter	4
			Ölpumpe, Kupplung, Kettenbremse	6
			Kurbelgehäuse, Gehäuseteile Tankverschluss, Haube	8
			Starter	10
			Handgriff / Hauptgehäuse, Haltebügel, Handschutz	12
			Schwert, Kette, Anschlagkralle, Kettenspannung	14
			Ersatzteile	16
			Richtlinien für die Bestellung	16

(GB) Spare parts list	Chain saw	656SP	Table of contents	Page
			Engine: Crankshaft, Cylinder, Ignition coil	2
			Exhaust, carburetor, air filter	4
			Oil-pump, clutch, chain brake	6
			Crankcase, tank cap, cover	8
			Starter	10
			Handle bar / main housing, hand protection	12
			Guide bar, chain, bucking spike, Tension screw / tension carriage	14
			Spare parts	16
			Directions for Ordering	16

(F) Liste de pièces de rechange	Tronçonneuses	656SP	Table des matières	Page
			Moteur : Embiellage, Cylindre, Bobine allumage	2
			Echappement, carburateur, filtre à air	4
			Pompe à huile, embrayage, frein de la chaîne	6
			Carter moteur bouchon réservoir, couvercle	8
			Lanceur	10
			Etrier / carter principal, protège main	12
			Guide chaîne, chaîne, griffe de butée, Vis de tension	14
			Pièces de rechange	16
			Directives pour les commandes	16

(E) Lista de piezas de recambio	Motosierras	656SP	Indice	Página
			Motor: Cigüenal, Cilindro, Bobina	2
			Escape, carburador, filtro de aire	4
			Bomba de aceite, embrague, freno de cadena	6
			Carter cigüenal, tapa de deposito, cubierta	8
			Arranque	10
			Asa / carter principal, proteccion de mano	12
			Espada, cadena, garra de apoyo, Tornillo de tension	14
			Piezas de recambio	16
			Directivas de pedido	16

Motoreinheit: Kurbelwelle,
Zylinder, Zündung

Engine: Crankshaft,
Cylinder, Ignition coil

Moteur : Embiellage,
Cylindre, Bobine allumage

Motor: Cigüenal, Cilindro,
Bobina

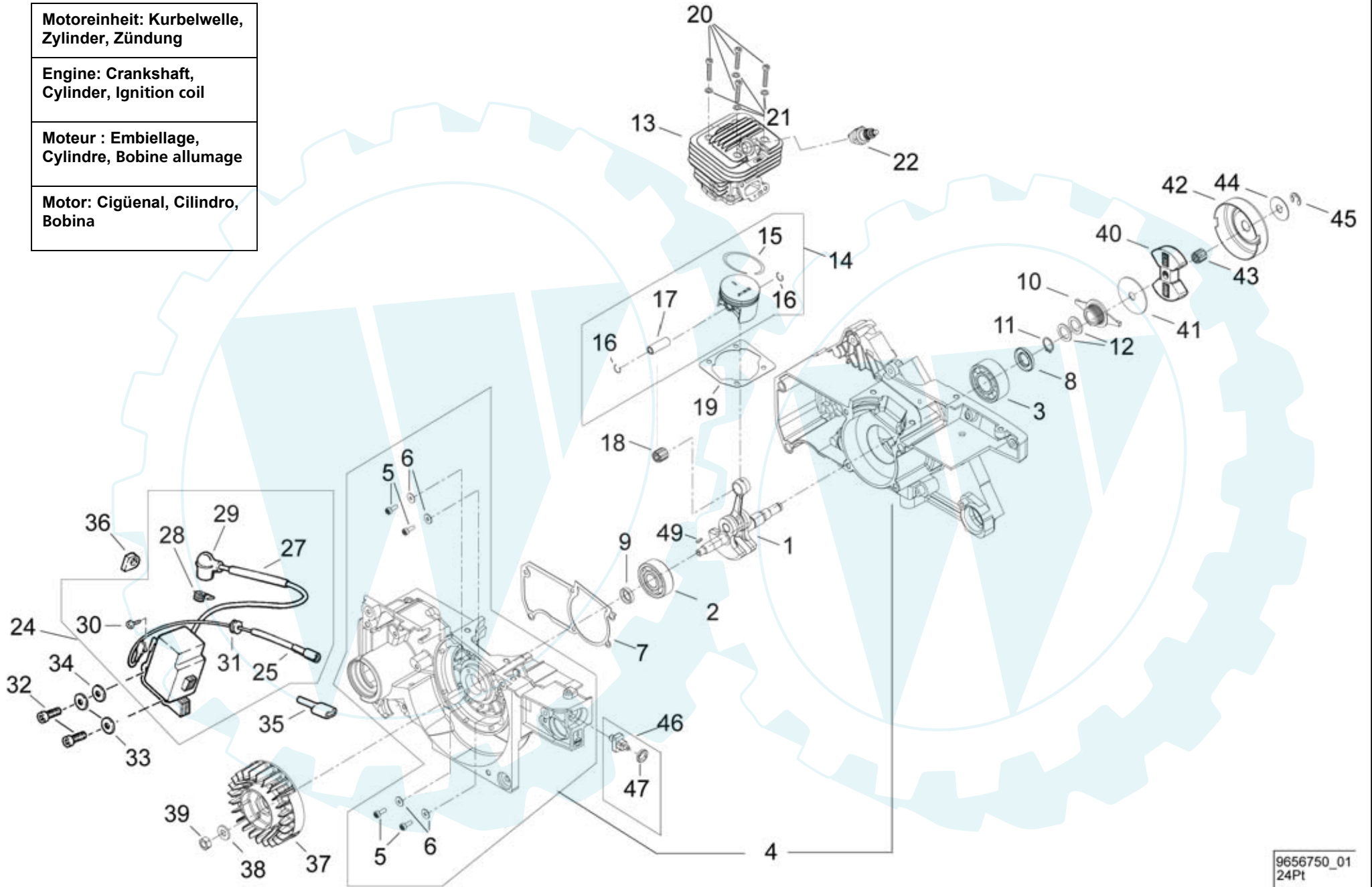

9656750_01
24Pt

Bild-Nr. Pos.-No. No.Pos. Pos.-No.	Bestell-Nr. Order-No. No. de Cde Ref.-Nr.	Menge Quantity Nombres Cantidad	Motoreinheit: Kurbelwelle, Zylinder, Zündung	Engine: Crankshaft, Cylinder, Ignition coil	Moteur : Embiellage, Cylindre, Bobine allumage	Motor: Cigüenal, Cilindro, Bobina
1	22 00 654 52	1	Kurbelwelle	Crankshaft	Embiellage	Cigüenal
2	00 50 187	1	Kugellager 12x32x10 mm	Ball bearing	Roulement à billes	Cojinete de bolas
3	00 50 188	1	Kugellager 15x35x13 mm	Ball bearing	Roulement à billes	Cojinete de bolas
4	21 00 659 44	1	Kurbelgehäuse enth. (-> 4 - 6	Crankcase incl. (-> 4 - 6	Carter-moteur y inclus (-> 4 - 6	Carter cigüenal incl. (-> 4 - 6
5	00 10 158	4	Zylinderschraube M5x25 mm	Screw	Vis	Tornillo
6	00 34 201	4	Sicherungsscheibe 5 mm<-)	Tension washer <-)	Rondelle de tension <-)	Arandela elastica <-)
7	20 61 473	1	Dichtung Kurbelgehäuse	Gasket	Joint	Junta
8	00 54 251	1	Wellendichtring 15x29,6x4 mm	Oil seal	Joint spy	Reten
9	00 54 252	1	Wellendichtring 12x19x5 mm	Oil seal	Joint spy	Reten
10	60 74 976	1	Mitnehmerschnecke	Activator	Entraineur à vis	Activador
11	00 55 136	1	Sicherungsring 15x1 mm	Circlip	Circlip	Anillo de seguridad
12	00 31 270	2	Scheibe 15x22x0,5 mm	Washer	Rondelle	Arandela
13	20 11 868	1	Nikasilzylinder Ø 47 mm	Cylinder	Cylindre	Cilindro
14	22 00 345	1	Kolben Ø 47 mm enth. (-> 14 - 17	Piston incl. (-> 14 - 17	Piston y inclus (-> 14 - 17	Piston incl. (-> 14 - 17
15	20 48 404	1	Kolbenring 47x1,5 mm	Piston ring	Segment	Anillo de piston
16	00 55 267	2	Sprengring 10x0,8 mm	Ring	Circlips d'axe de piston	Anillo
17	20 31 249 25	1	Kolbenbolzen 10/6,5x28 mm <-)	Piston pin <-)	Axe de piston <-)	Bulon <-)
18	00 52 255	1	Nadelkäfig 10x14x13 mm	Needle sleeve	Douille	Casquillo
19	20 61 524	1	Zylinderfußdichtung 0,5 mm	Cylinder foot gasket	Joint de cylindre	Junta del cilindro
20	00 10 604	4	Zylinderschraube M5x22 mm	Screw	Vis	Tornillo
21	00 34 201	4	Sicherungsscheibe 5 mm	Tension washer	Rondelle de tension	Arandela elastica
22	23 00 730	1	Zündkerze WSR6F200	Spark plug	Bougie	Bujia
24	23 00 752	1	Zündmodul Phelon enth. (-> 24 - 31	Ignition coil Phelon incl. (-> 24 - 31	Bobine Phelon y inclus (-> 24 - 31	Bobina Phelon incl. (-> 24 - 31
25	00 84 702	1	Kurzschlusskabel	Short circuit cable	Câble	Cable cortocircuito
27	00 64 292	110 mm	Schlauch 6x1 mm	Hose	Tuyau	Tube
28	00 73 347	1	Kontaktfeder	Contact spring	Ressort de contact	Resorte de contacto
29	00 84 621	1	Zündkerzenstecker	Spark plug cap	Capuchon de bougie	Terminal de bujia
30	00 10 128	1	Zylinderschraube M3x4 mm	Screw	Vis	Tornillo
31	00 66 335	1	Kabeltülle 2 <-)	Grommet <-)	Passe-fil <-)	Manguito de cable <-)
32	00 18 327	2	Zylinderschraube M4x20 mm	Screw	Vis	Tornillo
33	00 72 148	2	Spannscheibe 4 mm	Tension spring	Rondelle de tenison	Arandela elastica
34	00 30 101	1	Scheibe 4,3 mm	Washer	Rondelle	Arandela
35	00 66 314	1	Isoliertülle	Grommet	Passe-fil	Manguito de cable
36	20 63 333	1	Kabeltülle	Grommet	Douille	Manguito de cable
37	24 00 289 25	1	Lüfterrad 12	Fan wheel	Volant magnétique	Turbina
38	00 72 145	1	Spannscheibe 8 mm	Tension spring	Rondelle de tension	Arandela elastica
39	00 20 145	1	Sechskantmutter M8x1	Nut	Écrou	Tuerca
40	35 00 405	1	Fliehkraftkupplung M12x1,25	Centrifugal clutch	Embrayage centrifuge	Embrague centriefugal
41	60 42 817	1	Scheibe 12x55x1 mm	Washer	Rondelle	Arandela
42	35 00 362 25	1	Kupplungsglocke .325"	Clutch drum.325"	Cloche embrayage.325"	Campana embrague.325"
43	00 52 257	1	Nadelkäfig 10x13x13 mm	Needle sleeve	Douille	Casquillo
44	00 31 534	1	Scheibe 10x30x1mm	Washer	Rondelle	Arandela
45	00 55 104	1	Sicherungsscheibe 8 mm	Safety washer	Circlip	Seguro
46	23 00 469	1	Kurzschlusschalter enth. (-> 46, 47	Short circuit switch incl. (-> 46, 47	Interrupteur y inclus (-> 46, 47	Interruptor incl. (-> 46, 47
47	00 21 232	1	Rundmutter M12x0,75 <-)	Nut <-)	Écrou <-)	Tuerca <-)
49	00 75 100	1	Scheibenfeder 2x3,7 mm	Disc spring	Clavette	Chaveta

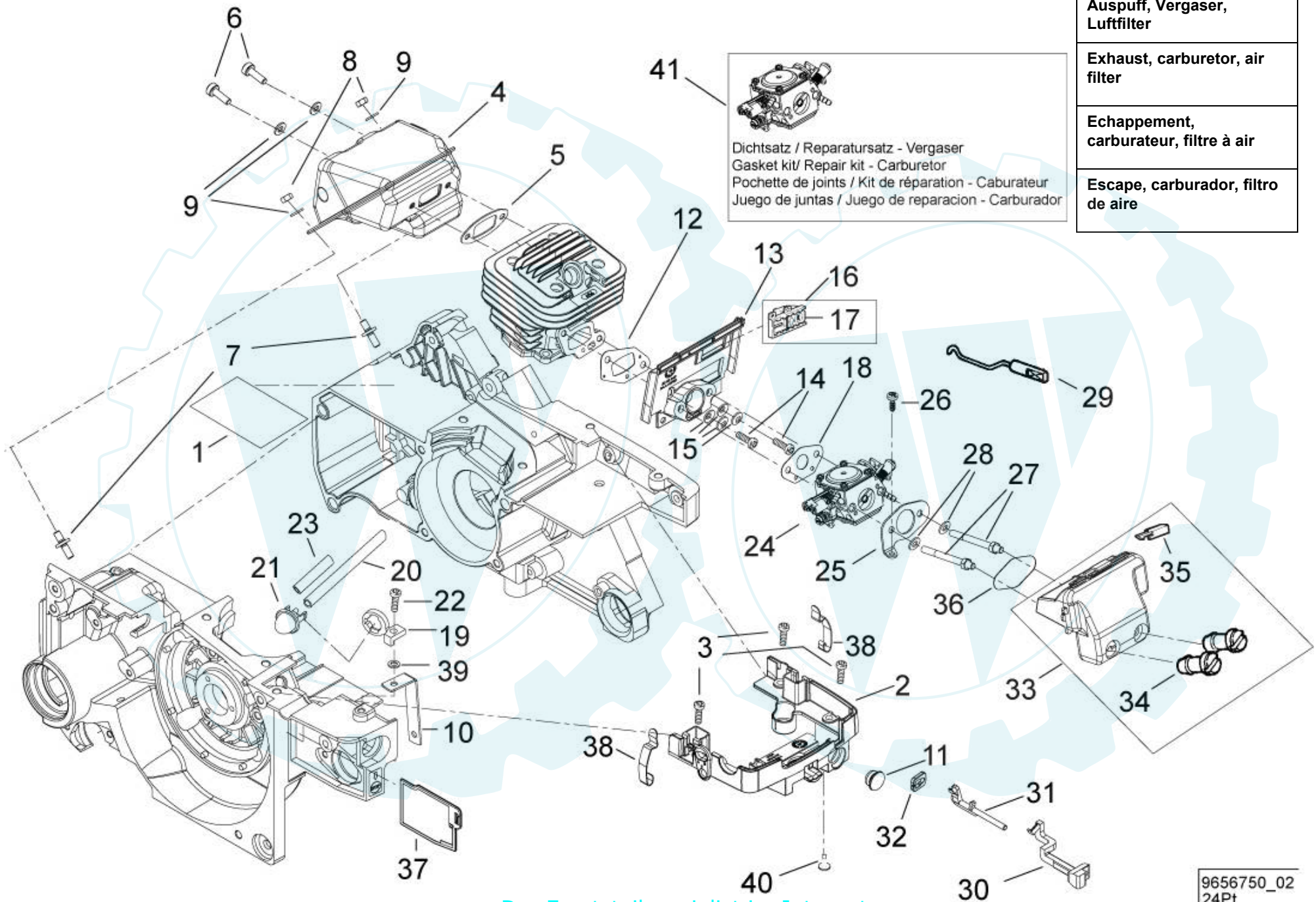

Auspuff, Vergaser, Luftfilter
Exhaust, carburetor, air filter
Echappement, carburateur, filtre à air
Escape, carburador, filtro de aire

41



Dichsatz / Reparatursatz - Vergaser
Gasket kit/ Repair kit - Carburetor
Pochette de joints / Kit de réparation - Carburateur
Juego de juntas / Juego de reparacion - Carburador

Bild-Nr. Pos.-No. Pos.-No.	Bestell-Nr. Order-No. No. de Cde Ref.-Nr.	Menge Quantity Nombres Cantidad	Auspuff, Vergaser, Luftfilter	Exhaust, carburetor, air filter	Echappement, carbureteur, filtre à air	Escape, carburador, filtro de aire
1	60 42 827	1	Isolierfolie	Isolating foil	Feuille isolatrice	Laminilla
2	60 73 363	1	Vergaserboden	Intermediate housing	Carter intermediaire	Carter intermedia
3	00 18 335	3	Zylinderschraube M5x12 mm	Screw	Vis	Tornillo
4	25 00 604 25	1	Auspuff	Exhaust	Échappement	Escape
5	20 61 442	1	Auspuffdichtung 2 mm dick	Muffler gasket	Joint amortisseur	Junta del escape
6	00 18 336	2	Zylinderschraube M5x16 mm	Screw	Vis	Tornillo
7	00 15 286	2	Stiftschraube M5x12 mm	Screw	Goujon	Tornillo
8	00 28 137	2	Sechskantmutter M5	Nut	Écrou frein m5	Tuerca
9	00 72 144	4	Sicherungsscheibe 5 mm	Tension washer	Rondelle de tension	Arandela elastica
10	00 98 122	1	Fangsicherung	Safety catch	Frein	Seguridad
11	60 74 401	1	Verschlussstopfen	Plug	Bouchon	Tapon
12	20 61 436	1	Vergaserstutzendichtung 0,5 mm dick	Manifold gasket	Joint d'admission	Junta carburador
13	23 00 842 01	1	Vergaserstutzen	Manifold	Pipe d'admission	Munon carburador
14	00 10 158	2	Zylinderschraube M5x25 mm	Screw	Vis	Tornillo
15	00 34 201	4	Sicherungsscheibe 5 mm	Tension washer	Rondelle de tension	Arandela elastica
16	25 00 820	1	Verschluss Winter/Sommer enth. (-> 16, 17	Plug incl. (-> 16, 17	Bouchon y inclus (-> 16, 17	Topón incl. (-> 16, 17
17	20 74 469	1	Verschlusschieber <-)	Plug <-)	Bouchon <-)	Topón <-)
18	20 61 443	1	Flanschdichtung 0,5 mm dick	Carburetor gasket	Joint carburateur	Junta
19	60 74 958	1	Halter Primer	Primer support	Support pour primer	Soporte
20	00 64 432	1	Schlauch 3x1,5x100	hose	tuyau	tubo
21	27 00 322	1	Primer	Primer	Pompe d'amorçage	Cabador
22	00 18 337	1	Zylinderschraube M5x20 mm	Screw	Vis	Tornillo
23	00 64 407	26 mm	Schlauch 2x1,5x	Hose	Tuyau	Tubo
24	23 00 858	1	Vergaser, HDA 170B	Carburetor	Carburateur	Carburador
25	60 43 247	1	Vergaserstütze	Support	Tôle	Soporte
26	00 18 354	1	Linsenschraube 4x12	Screw	Vis	Tornillo
27	00 15 279	2	Stiftschraube M5x46	Screw	Boulon fileté	Tornillo
28	00 34 147	2	Federring 5	Spring ring	Rondelle grover	Anillo elastico
29	28 00 285 25	1	Gasgestänge 1	Throttle linkage	Tringlerie des gaz	Varilla
30	60 74 993	1	Chokehebel	Choke lever	Levier choke	Palanca choke
31	60 74 992	1	Halbgasstift	Pin	Boulon	Perno
32	60 63 156	1	Chokehebellagerung	Choke lever seat	Palier de levier choke	Apoyo del palanca choke
33	25 00 641	1	Luftfilter, vollst enth. (-> 33-35	Air filter incl. (-> 33-35	Filtre à air, compl., y inclus (-> 33-35	Filtro de aire, incl. (-> 33-35
34	00 11 282	2	Filterschraube M5x12,5	Screw	Vis	Tornillo
35	20 74 946	1	Klemmprofil 4x2x20 <-)	Profile <-)	Profil <-)	Perfil <-)
36	00 62 246	1	O-Ring 30x2,5	O-ring	Joint torique	Anillo
37	25 00 502	1	Vorfilter	Pre-filter assembly	Filtre	Filtro
38	00 73 108	2	Federstahlklammer	Fasatening clips	Clips de fixation	Pinza de fijación
39	00 34 201	1	Sicherungsscheibe 5 mm	Tension washer	Rondelle de tension	Arandela elastica
40	00 94 294	1	Puffer	Buffer	Butee caoutchouc	Tope
41	05 10 952	1	Dichtsatz / Reparatursatz - Vergaser	Gasket-kit / Repair-kit - carburetor	Pochette de joints / Kit de réparation - carburateur	Juego de juntas / Juego de reparacion - carburador

Ölpumpe, Kupplung, Kettenbremse
Oil-pump, clutch, chain brake
Pompe à huile, embrayage, frein de la chaîne
Bomba de aceite, embrague, freno de cadena

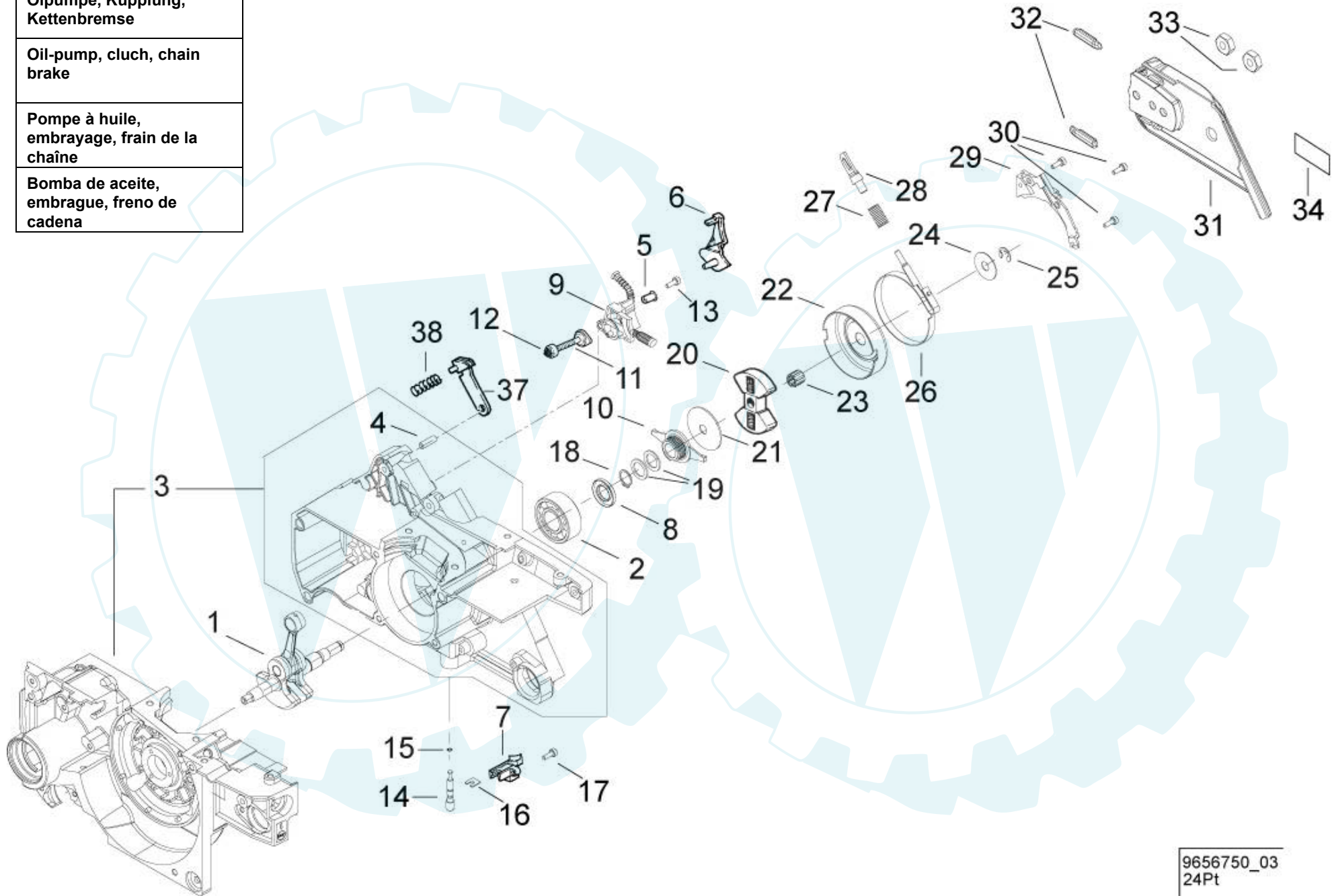

9656750_03
24Pt

Bild-Nr. Pos.-No. No.Pos. Pos.-No.	Bestell-Nr. Order-No. No. de Cde Ref.-Nr.	Menge Quantity Nombres Cantidad	Ölpumpe, Kupplung, Kettenbremse	Oil-pump, clutch, chain brake	Pompe à huile, embrayage, frein de la chaîne	Bomba de aceite, embrague, freno de cadena
1	22 00 654 52	1	Kurbelwelle	Crankshaft	Embiellage	Cigüenal
2	00 50 188	1	Kugellager 15x35x13	Ball bearing	Roulement à billes	Cojinete de bolas
3	21 00 659 44	1	Kurbelgehäuse enth. (-> 3, 4	Crankcase incl. (-> 3, 4	Carter-moteur y inclus (-> 3, 4	Carter cigüenal incl. (-> 3, 4
4	00 40 190	1	Zylinderstift M6x14 mm <-)	Pin <-)	Goujon <-)	Perno <-)
5	00 44 271	1	Rohrniet	Rivet	Rivet	Remache
6	60 74 447	1	Abdeckkappe	Cover	Couvercle	Cubierta
7	60 74 409	1	Anschlagstück	Stop plate	Butée	Pieza
8	00 54 251	1	Wellendichtring 15x29,6x4 mm	Oil seal	Joint spy	Reten
9	64 00 229	1	Ölpumpe	Oil pump	Pmpe à hulle	Juego bomba
10	60 74 976	1	Mitnehmerschnecke	Activator	Entraîneur à vis	Activador
11	60 63 329	1	Ölschlauch 3,5x88	Oil hose	Tuyau d'huile	Tube de aceite
12	67 00 124	1	Ölsieb	Oil strainer	Tamis à huile	Tamiz de aceite
13	00 10 603	1	Zylinderschraube M4x12 mm	Screw	Vis	Tornillo
14	64 00 156	1	Hubstift 3/5,8x14/36,6	Pin	Goujon	Perno
15	00 62 256	1	O-Ring 4x1,2	O-ring	Joint torique	Anillo
16	20 42 726	1	Anschlagblech	Stop plate	Plaque d'arrêt	Chapa
17	00 18 280	1	Zylinderschraube M4x12 mm	Screw	Vis	Tornillo
18	00 55 136	1	Sicherungsring 15x1 mm	Circlip	Circlip	Anillo de seguridad
19	00 31 270	2	Scheibe 15x22x0,5 mm	Washer	Rondelle	Arandela
20	35 00 405	1	Fliehkraftkupplung M12x1,25	Centrifugal clutch	Embrayage centrifuge	Embrague centriefugal
21	60 42 817	1	Scheibe 12x55x1 mm	Washer	Rondelle	Arandela
22	35 00 362 25	1	Kupplungsglocke .325"	Clutch drum.325"	Cloche embrayage.325"	Campana embrague .325"
23	00 52 257	1	Nadelkäfig 10x13x13 mm	Needle sleeve	Douille	Casquillo
24	00 31 534	1	Scheibe 10x30x1mm	Washer	Rondelle	Arandela
25	00 55 104	1	Sicherungsscheibe 8 mm	Safety washer	Circlip	Seguro
26	62 00 131 25	1	Bremsband	Brake band	Ruban frein	Cinto del freno
27	00 70 254	1	Druckfeder 1,6x10,2x56	Spring	Ressort	Resorte de presión
28	63 00 208 25	1	Verstellung	Adjuster	Réglage	Regulación
29	60 74 999	1	Bremsbandabdeckung	Brake band cover	Boîte ruban frein	Cubierta del cinta del freno
30	00 18 280	3	Zylinderschraube M4x12 mm	Screw	Vis	Tornillo
31	60 11 728 25	1	Schwertabdeckung	Chain guard	Carter de chaîne	Cubierta espada
32	60 74 696	2	Gleitschuh	Guide shoe	Patin	Patin
33	00 20 214	2	Sechskantmutter M8	Nut	Écrou	Tuerca
34	00 69 788	1	Selbstklebeschild "SOLO"	Sticker	Autocollant	Adhesivo
37	63 00 175 25	1	Druckblech	Pressure plate	Tôle	Chapa de presión
38	00 70 253	1	Druckfeder 1,5x7x21,5	Spring	Ressort	Resorte

Kurbelgehäuse, Gehäuseteile
Tankverschluss, Haube

Crankcase, tank cap, cover

Carter moteur bouchon
réservoir, couvercle

Carter cigüenal, tapa de
deposito, cubierta



Bild-Nr. Pos.-No. No.Pos. Pos.-No.	Bestell-Nr. Order-No. No. de Cde Ref.-Nr.	Menge Quantity Nombres Cantidad	Kurbelgehäuse, Gehäuseteile Tankverschluss, Haube	Crankcase, tank cap, cover	Carter moteur bouchon réservoir, couvercle	Carter cigüenal, tapa de deposito, cubierta
1	21 00 659 44	1	Kurbelgehäuse enth. (-> 1 - 5	Crankcase incl. (-> 1 - 5	Carter-moteur y inclus (-> 1 - 5	Carter cigüenal incl. (-> 1 - 5
2	00 10 158	4	Zylinderschraube M5x25 mm	Screw	Vis	Tornillo
3	00 34 201	4	Sicherungsscheibe 5 mm	Tension washer	Rondelle de tension	Arandela elastica
4	00 40 190	1	Zylinderstift M6x14 mm	Pin	Goujon	Perno
5	00 18 398	2	Stiftschraube M8x18,5 mm <-)	Screw <-)	Vis <-)	Tornillo <-)
6	27 00 382	1	Rückschlagventil	check valve	soupape antiretour	valvula
7	20 61 473	1	Dichtung Kurbelgehäuse	Gasket	Joint	Junta
8	60 42 827	1	Isolierfolie	Isolating foil	Feuille isolatrice	Laminilla
9	27 00 414	1	Entlüftungsstutzen	Ventilation socket	Manchon d'aération	Munon
10	00 64 300	170 mm	Schlauch 3x1,5mm Entlüftung	Ventilation hose	Tuyau d'aération	Tubo
11	00 73 279	1	Schlauchöse 6,5 / 5,8 x0,9x4 mm	Grommet	Collier	Manguito de cable
12	60 73 363	1	Vergaserboden	Intermediate housing	Carter intermediaire	Carter intermedia
13	00 18 335	3	Zylinderschraube M5x12 mm	Screw	Vis	Tornillo
14	00 44 289	1	Kunststoff Niet	Rivet	Rivet	Remache
15	00 68 266	1	Selbstklebeschild "STOP"	Sticker "STOP"	Autocollant "STOP"	Placa "STOP"
16	00 44 271	1	Rohrniet	Rivet	Rivet	Remache
17	60 74 447	1	Abdeckkappe	Cover	Couvercle	Cubierta
18	60 43 330	1	Kettenführungsblech	Guide plate	Tôle de guidage	Chapa
19	00 13 282	1	Linienblechschraube 3,5x9,5 mm	Screw	Vis	Tornillo
20	64 00 229	1	Ölpumpe	Oil pump	Pmpe à hulle	Juego bomba
21	60 63 329	1	Ölschlauch 3,5x88	Oil hose	Tuyau d'huile	Tubo de aceite
22	67 00 124	1	Ölsieb	Oil strainer	Tamis à huile	Tamiz de aceite
23	00 10 603	1	Zylinderschraube M4x12 mm	Screw	Vis	Tornillo
24	27 00 326	1	Tankverschluss, Öl enth. (-> 24, 25	Oil tank cap incl. (-> 24, 25	Bouchon réservoir huile y inclus (-> 24, 25	Tapa de deposito incl. (-> 24, 25
25	00 62 147	1	O-Ring 25,3x2,4 mm <-)	O-ring <-)	Joint torique <-)	Anillo <-)
26	63 00 155	4	Schwingmetall 20,3/10x22,5	Rubber metal conn.	Silent bloc	Elemento
27	60 74 422	2	Schutzdeckel	Protective cap	Capuchon de protection	Tapa proteccion
28	60 43 352	1	Kettenfangblech	Chain protection plate	Tôle guide	Chapa parador de cadena
29	00 18 274	3	Linsenschraube 5x16 mm	Screw	Vis	Tornillo
30	00 18 280	4	Zylinderschraube M4x12 mm	Screw	Vis	Tornillo
31	00 18 257	1	Linsenschraube 5x25 mm	Screw	Vis	Tornillo
32	00 33 318 25	1	Distanzrohr 9x1,85x9 mm	Spacer tube	Entretoise	Tubo distanciador
33	00 98 143	1	Fangsicherung 4	Safety catch	Frein	Seguridad
34	00 30 115	1	Scheibe 4,3mm	Washer	Rondelle	Arandela
35	00 98 122	1	Fangsicherung	Safety catch	Frein	Seguridad
36	23 00 469	1	Kurzschlusschalter enth. (-> 36, 37	Short circuit switch incl. (-> 36, 37	Interrupteur y inclus (-> 36, 37	Interruptor incl. (-> 36, 37
37	00 21 232	1	Rundmutter M12x0,75 <-)	Nut <-)	Écrou <-)	Tuerca <-)
38	60 74 401	1	Verschlussstopfen	Plug	Bouchon	Tapon
39	60 74 958	1	Halter Primer	Primer support	Support pour primer	Soporte
40	00 64 432	1	Schlauch 3x1,5x100	hose	tuyau	tubo
41	27 00 322	1	Primer	Primer	Pompe d'amorçage	Cabador
42	00 18 337	1	Zylinderschraube M5x20 mm	Screw	Vis	Tornillo
43	00 64 407	26 mm	Schlauch 2x1,5x	Hose	Tuyau	Tubo
44	60 74 993	1	Chokehebel	Choke lever	Levier choke	Palanca choke
45	60 74 992	1	Halbgasstift	Pin	Boulon	Perno
46	60 63 156	1	Chokehebellagerung	Choke lever seat	Palier de levier choke	Apoyo del palanca choke
47	63 00 175 25	1	Druckblech	Pressure plate	Tôle	Chapa de presión
48	00 70 253	1	Druckfeder 1,5x7x21,5	Spring	Ressort	Resorte
49	00 73 109	1	Federstahlklammer	Fasatening clips	Clips de fixation	Pinza de fijación
50	61 00 462	1	Haube, rot enth. (-> 50 - 55	Cover, red incl. (-> 50 - 55	Couvercle, rouge y inclus (-> 50 - 55	Cubierta, rojo incl. (-> 50 - 55
51	00 36 185	1	Verschlussstopfen	Plug	Bouchon	Tapon
52	60 42 827	1	Isolierfolie	Isolating foil	Feuille isolatrice	Laminilla
53	00 68 220	1	Selbstklebeschild "Gehörschutz"	Sticker	Autocollant	Adhesivo
54	00 94 252	1	Distanzstück	Rubber spacer	Cale caoutchouc	Elemento de goma
55	00 36 176	1	Verschlussstopfen <-)	Plug <-)	Bouchon <-)	Tapon <-)
56	00 68 372	1	Selbstklebeschild "SOLO 656 SP"	Sticker	Autocollant	Adhesivo
57	00 73 108	2	Federstahlklammer	Fasatening clips	Clips de fixation	Pinza de fijación
58	00 94 294	1	Puffer	Buffer	Butee caoutchouc	Tope
59	00 34 201	1	Sicherungsscheibe 5 mm	Tension washer	Rondelle de tension	Arandela elastica

Starter
Starter
Lanceur
Arranque

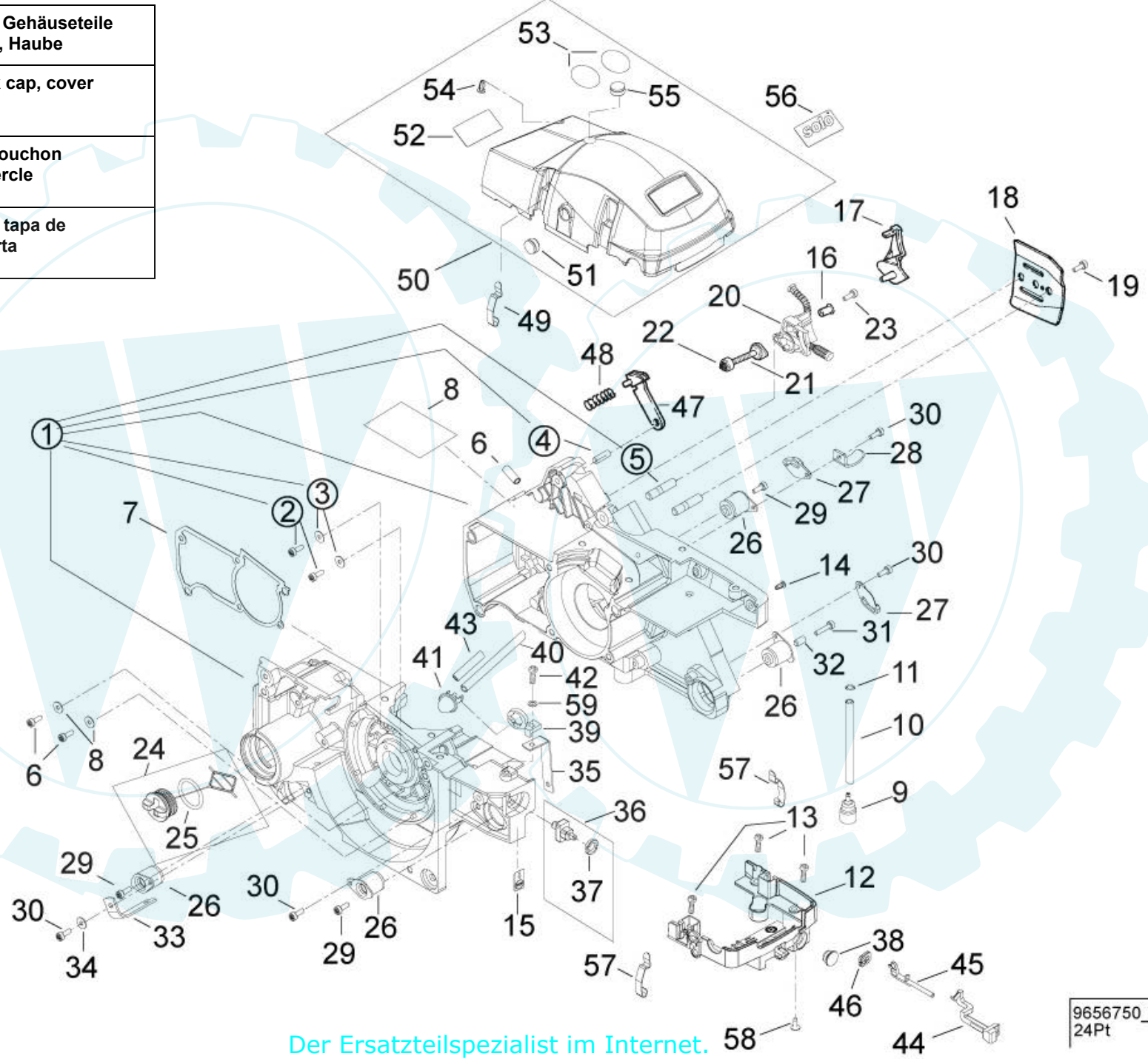
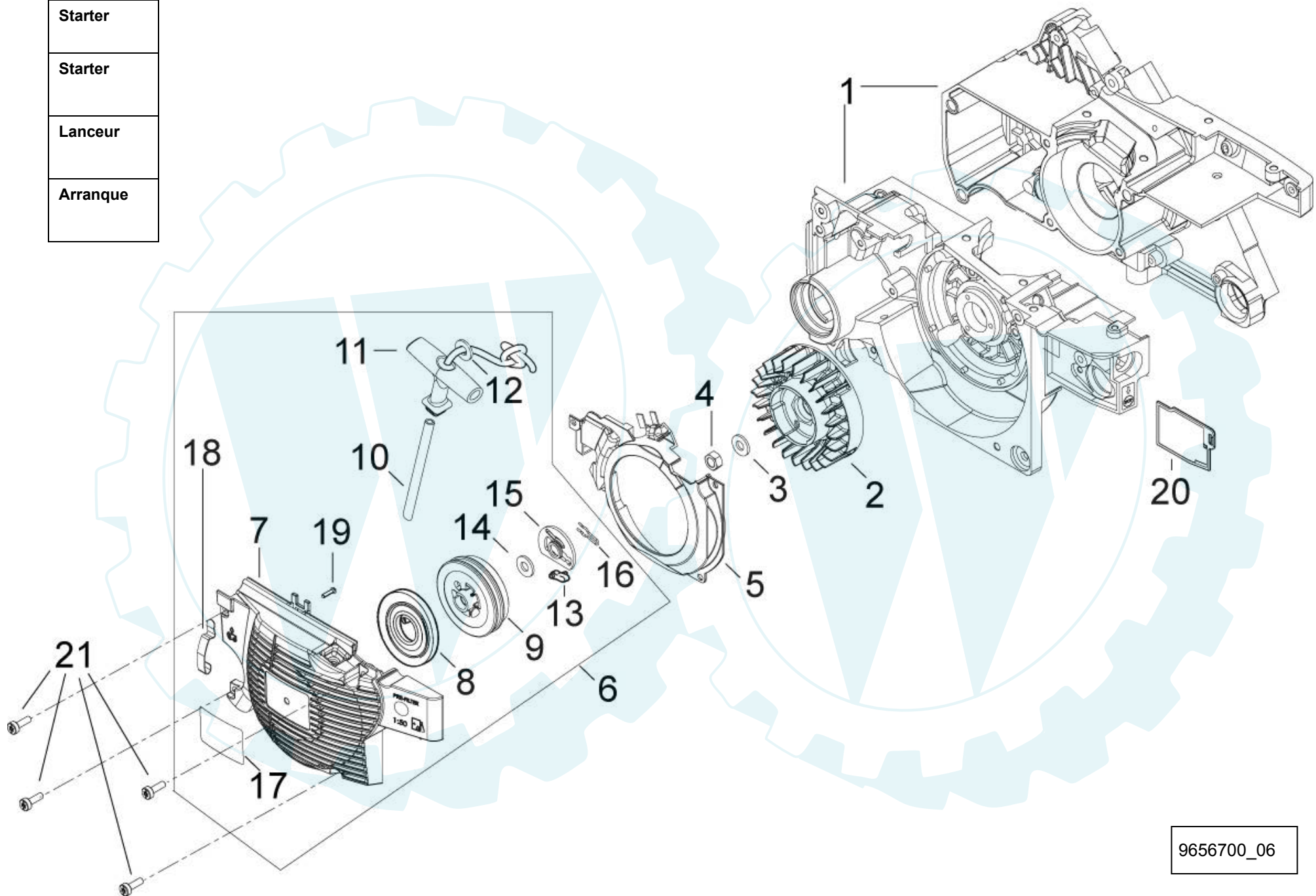

9656700_06

Bild-Nr. Pos.-No. No.Pos. Pos.-No.	Bestell-Nr. Order-No. No. de Cde Ref.-Nr.	Menge Quantity Nombres Cantidad	Starter	Starter	Lanceur	Arranque
1	21 00 659 44	1	Kurbelgehäuse	Crankcase	Carter-moteur	Carter cigüenal
2	24 00 289 25	1	Lüfterrad 12	Fan wheel	Volant magnétique	Turbina
3	00 72 145	1	Spannscheibe 8	Tension spring	Rondelle de tension	Arandela elastica
4	00 20 145	1	Sechskantmutter M8x1	Nut	Écrou	Tuerca
5	60 73 695	1	Lufführung	Air guide	Conduit d'air	Guia aire
6	26 00 327	1	Starter kompl. enth. (-> 6 - 19)	Starter compl. incl. (-> 6 - 19)	Lanceur compl. y inclus (-> 6 - 19)	Arranque compl. incl. (-> 6 - 19)
7	26 00 335	1	Startergehäuse	Starter housing	Carter lanceur	Caja de arranque
8	26 00 283	1	Federkassette	Spring cassette	Cassette de ressort	Caja de resorte
9	20 74 419 25	1	Seilrolle	Rope pulley	Poulie de câble	Roldana
10	00 63 186 25	1	Starterseil	Starter rope	Câble de lanceur	Cuerda de arranque
11	60 74 709	1	Startergriff	Starter handle	Poignée de lanceur	Empunadura
12	00 72 148	1	Spannscheibe 4mm	Tension spring	Rondelle de tension	Arandela elastica
13	20 74 209 25	1	Starterklinke	Starter pawl	Cliquet de lanceur	Trinquete
14	00 31 260	1	Scheibe 10x 16x0,5 mm	Washer	Rondelle	Arandela
15	20 74 408 25	1	Kulisse	Template	Coulisse	Colisa
16	00 73 365	1	Federstecker 1,4	Pin	Goupille beta	Clavija
17	00 69 889	1	Selbstklebeschild "SOLO"	Decal "SOLO"	Autocollant "SOLO"	Etiqueta "SOLO"
18	00 73 109	1	Federstahlklammer	Fasatening clips	Clips de fixation	Pinza de fijación
19	00 42 301	1	Kerbnagel <-)	Nail <-)	Clou cannele <-)	Clavo <-)
20	25 00 502	1	Vorfilter	Pre-filter	Filtre	Filtro
21	00 18 336	4	Zylinderschraube M5x10 mm	Screw	Vis	Tornillo

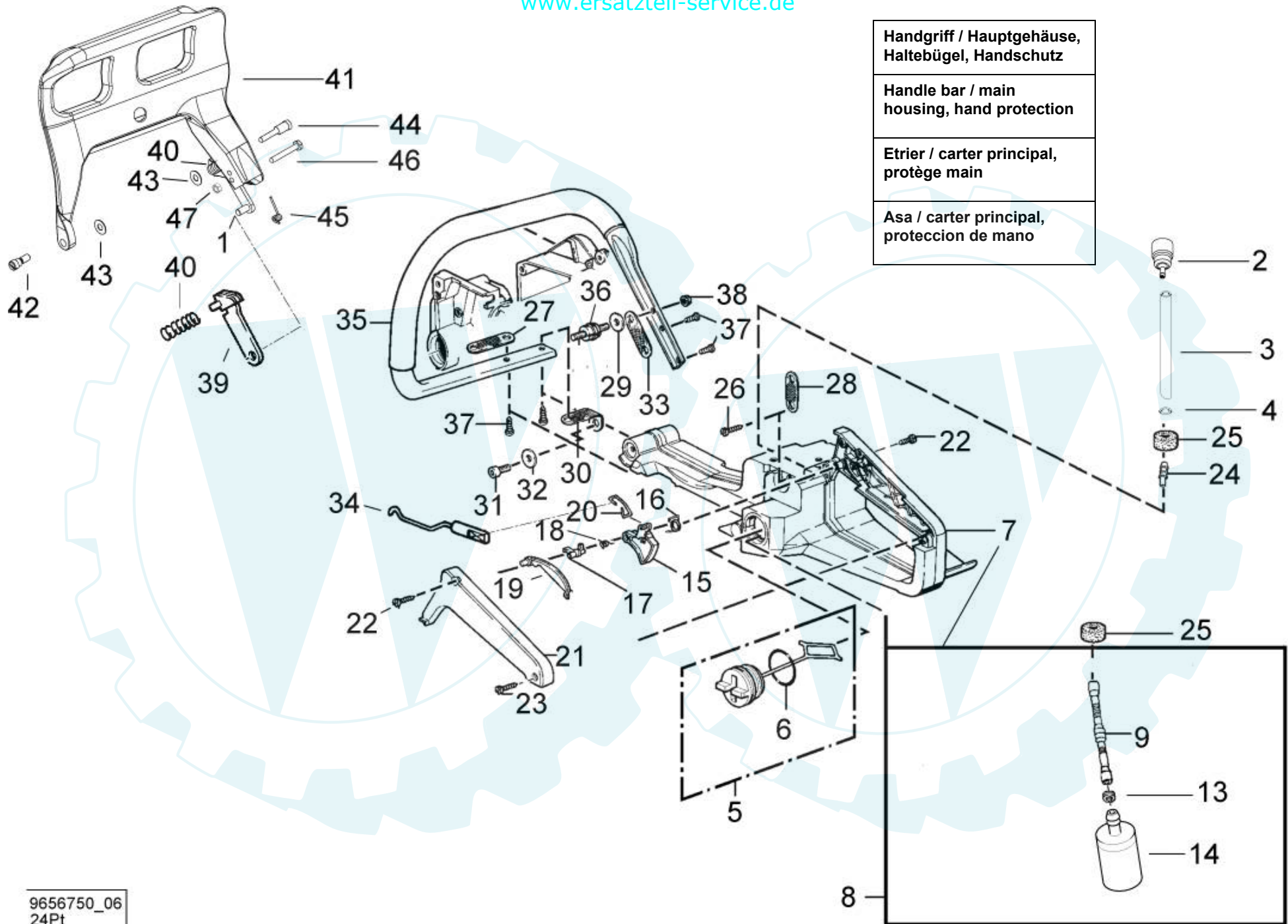

9656750_06
24Pt

Bild-Nr. Pos.-No. No.Pos. Pos.-No.	Bestell-Nr. Order-No. No. de Cde Ref.-Nr.	Menge Quantity Nombres Cantidad	Handgriff / Hauptgehäuse, Haltebügel, Handschutz	Handle bar / main housing, hand protection	Etrier / carter principal, protège main	Asa / carter principal, proteccion de mano
1	00 40 190	1	Zylinderstift M6x14 mm	Pin	Goujon	Perno
2	27 00 414	1	Entlüftungsstutzen	Ventilation socket	Manchon d'aération	Munon
3	00 64 300	170 mm	Schlauch 3x1,5mm Entlüftung	Ventilation hose	Tuyau d'aération	Tubo
4	00 73 279	1	Schlauchöse 6,5 / 5,8 x0,9x4 mm	Grommet	Collier	Manguito de cable
5	27 00 353	1	Tankverschluss, Benzin enth. (-> 5, 6	Tank cap incl. (-> 5, 6	Bouchon réservoir y inclus (-> 5, 6	Tapa de deposito incl. (-> 5, 6
6	00 61 356	1	Dichtung 25x37x2,2 mm (-)	Gasket (-)	Joint (-)	Junta (-)
7	61 00 456	1	Hauptgehäuse enth. (-> 7 - 14	Main housing incl. (-> 7 - 14	Carter principal y inclus (-> 7 - 14	Carter principal incl. (-> 7 - 14
8	27 00 354	1	Benzinsucher, kompl. enth. (-> 8 - 14	Fuel pick-up, compl. incl. (-> 8 - 14	Crépine d'essence, cpl. y inclus (-> 8 - 14	Busador, compl. incl. (-> 8 - 14
9	60 63 341	1	Kraftstoffschlauch 3x178	Fuel hose	Tuyau	Tubo gasolina
13	00 73 351	1	Schlauchöse	Tube eye	Collier	Ojete
14	27 00 135	1	Benzinsucher (-))	Fuel pick-up (-))	Crépine d'essence (-))	Busador (-))
15	20 74 429	1	Gashebel	Gas lever	Gachette gaz	Acelerador
16	00 73 392	1	Gashebelfeder	Throttle control spring	Ressort de gachette	Resorte acelerador
17	60 74 292	1	Blockierhebel	Stop lever	Lever de blocage	Palanca
18	00 73 339	1	Drehfeder 0,7x7,7	Spring	Ressort	Resorte
19	60 74 443	1	Sicherungshebel	Safety lever	Levier de sécurité	Palanca de seguro
20	20 36 381	1	Gasgestänge 2	Throttle linkage	Tringlerie des gaz	Varillaje de gas
21	60 73 681 25	1	Griffschale, links	Grip cup, left	Coquille d'étrier, gauche	Cascara
22	00 10 531	2	Blechschaube 4,2x19	Screw	Vis	Tornillo
23	00 10 512	1	Blechschaube 4,2x22	Screw	Vis	Tornillo
24	00 67 124	1	Schlauchnippel 3,6x16	Nipple	Raccord	Racor
25	60 63 301	2	Schlauchdurchführung	Hose guide	Oeillet	Ojete de tubo
26	00 18 274	1	Linsenschraube 5x16 mm	Screw	Vis	Tornillo
27	00 98 143	1	Fangsicherung 4	Safety catch	Frein	Seguridad
28	00 98 122	1	Fangsicherung	Safety catch	Frein	Seguridad
29	00 30 108	1	Scheibe 5,3	Washer	Rondelle	Arandela
30	00 98 142	1	Fangsicherung 3	Safety catch	Frein	Seguridad
31	00 10 157	1	Zylinderschraube M5x10	Screw	Vis	Tornillo
32	00 30 102	1	Scheibe 5,3	Washer	Rondelle	Arandela
33	00 98 141	1	Fangsicherung 2	Safety catch	Frein	Seguridad
34	28 00 285 25	1	Gasgestänge 1	Throttle linkage	Tringlerie des gaz	Varilla
35	68 00 241 25	1	Haltebügel	Handle bar	Étrier	Asa
36	00 94 288	1	Kerblager	Rubber metal connexion	Silentbloc	Elemento amortiguador
37	00 18 274	4	Linsenschraube 5x16 mm	Screw	Vis	Tornillo
38	00 28 130	1	Sechskantmutter M5	Nut	Écrou	Tuerca
39	63 00 175 25	1	Druckblech	Pressure plate	Tôle	Chapa de presión
40	00 70 253	1	Druckfeder 1,5x7x21,5	Spring	Ressort	Resorte
41	68 00 239	1	Handschutz	Hand protection	Protège main	Proteccion de mano
42	00 18 120	1	Lagerschraube M5x14	Screw	Vis	Tornillo
43	00 72 140	2	Scheibe 5,2x12x0,5 mm	Spring washer	Rondelle	Muelle de disco
44	60 32 639	1	Lagerschraube M5x20	Screw	Vis	Tornillo
45	00 73 439	1	Drehfeder 1,3x6,8	Torsion spring	Ressort	Resorte
46	60 32 669	1	Schaltbolzen M4x32,1 mm	Shift bolt	Axe commande	Bulon
47	00 28 118	1	Sechskantmutter M4	Nut	Écrou	Tuerca

Schwert, Kette, Anschlagkralle, Kettenspannung
Guide bar, chain, bucking spike, Tension screw / tension carriage
Guide chaîne, chaîne, griffe de butée, Vis de tension
Espada, cadena, garra de apoyo, Tornillo de tension

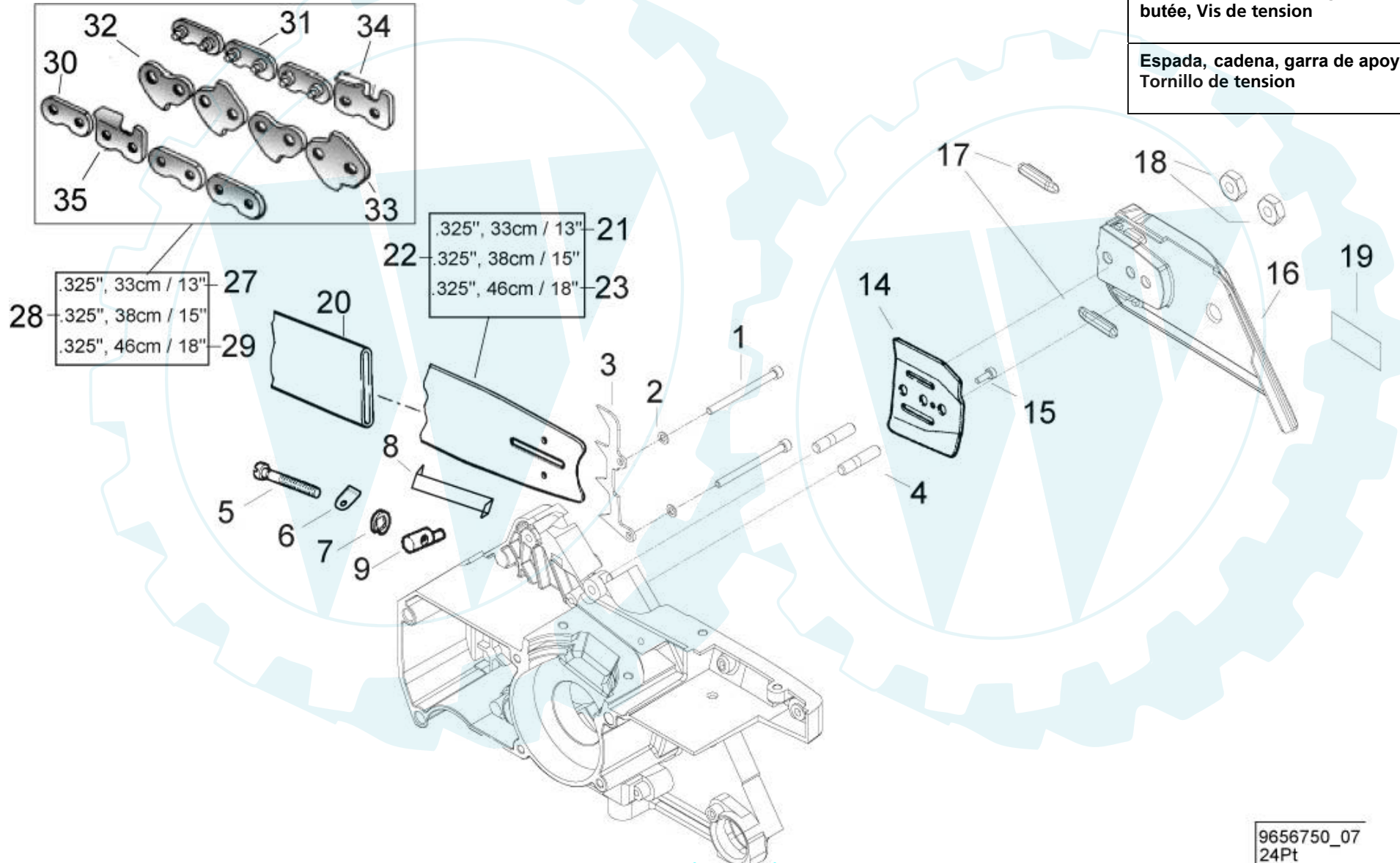

Der Ersatzteilspezialist im Internet.

9656750_07
24Pt

Bild-Nr. Pos.-No. Pos.-No.	Bestell-Nr. Order-No. No. de Cde Ref.-Nr.	Menge Quantity Nombres Cantidad	Schwert, Kette, Anschlagkralle, Kettenspannung	Guide bar, chain, bucking spike, Tension screw / tension carriage	Guide chaîne, chaîne, griffe de butée, Vis de tension	Espada, cadena, garra de apoyo, Tornillo de tension
1	00 10 559	2	Zylinderschraube M5x65 mm	Screw	Vis	Tornillo
2	00 34 201	2	Sicherungsscheibe 5 mm	Tension washer	Rondelle de tension	Arandela elastica
3	60 43 351	1	Anschlagkralle	Bucking spike	Griffe de butée	Garra de apoyo
4	00 18 398	2	Stiftschraube M8x18,5 mm	Screw	Vis	Tornillo
5	00 18 420	1	Einstellschraube M5 x 50	F. H. Screw	Vis t. c.	Tornillo
6	60 74 126	1	Lagerung	Support	Support	Soporte
7	00 55 101	1	Sicherungsscheibe 4 mm	Tension washer	Rondelle de tension	Arandela elastica
8	60 43 651	1	Führungsblech	Plate	Tôle	Chapa
9	60 32 641	1	Kettenspanbolzen M5	Chain tension bolt	Tendeure de chaîne	Perno de fijacion de cad.
14	60 43 330	1	Kettenführungsblech	Guide plate	Tôle de guidage	Chapa
15	00 13 285	1	Linensblechschraube 3,5x9,5 mm	Screw	Vis	Tornillo
16	60 11 728 25	1	Schwertabdeckung	Chain guard	Carter de chaîne	Cubierta espada
17	60 74 696	2	Gleitschuh	Guide shoe	Patin	Patin
18	00 20 214	2	Sechskantmutter M8	Nut	Écrou	Tuerca
19	00 69 788	1	Selbstklebeschild "SOLO"	Sticker	Autocollant	Adhesivo
20	60 71 258	1	Kettenschutz	Scabbrad	Fourreau de chaîne	Proteccion cadena
21	69 00 342		Führungsschiene, .325", 33 cm (13")	Guide bar, .325", 33 cm (13")	Guide, .325", 33 cm (13")	Espada, .325", 33 cm (13")
22	69 00 343		Führungsschiene, .325", 38 cm (15")	Guide bar, .325", 38 cm (15")	Guide, .325", 38 cm (15")	Espada, .325", 38 cm (15")
23	69 00 861		Führungsschiene, .325", 46 cm (18")	Guide bar, .325", 46 cm (18")	Guide, .325", 46 cm (18")	Espada, .325", 46 cm (18")
27	69 00 704		Halbmeiselkette 33 cm (13").325" 56 Treibglieder enth. (-> 30 - 35	Chain 13" (33 cm) incl. (-> 30 - 35	Chaîne 13" (33 cm) y inclus (-> 30 - 35	Cadena 13" (33 cm) incl. (-> 30 - 35
28	69 00 875		Halbmeiselkette 38 cm (15").325" 64 Treibglieder enth. (-> 30 - 35	Chain 15" (38 cm) incl. (-> 30 - 35	Chaîne 15" (38 cm) y inclus (-> 30 - 35	Cadena 15" (38 cm) incl. (-> 30 - 35
29	69 00 884		Halbmeiselkette 46cm (18").325" 72 Treibglieder enth. (-> 30 - 35	Chain 18" (46 cm) incl. (-> 30 - 35	Chaîne 18" (46 cm) y inclus (-> 30 - 35	Cadena 18" (46 cm) incl. (-> 211 - 216
30	05 40 205		Verbindungsglied, ohne Niet	Connection link w/o rivet	Maillon sans rivet	Eslabon de connexion
31	05 40 249		Verbindungsglied mit Niet	Connection link with rivet	Maillon avec rivet	Eslabon con remache
32	05 40 250		Treibglied	Drive link	Maillon entraineur	Eslabon de mango
33	05 40 251		Sicherheitstreibglied	Safety conn.	Maillon de sécurité	Eslabon
34	05 40 203		Linksschneider	Left cutter	Gouge gauche	Cortador izquierda
35	05 40 204		Rechtsschneider (-)	Right cutter (-)	Gouge droite (-)	Cortador derecha (-)

Bestell-Nr. Order-No. No. de Cde Ref.-Nr.	Menge Quantity Nombres Cantidad	Seite Page Page Pagina
00 10 128	1	2
00 10 157	1	12
00 10 158	4	2
00 10 158	2, 4	4, 8
00 10 512	1	12
00 10 531	2	12
00 10 559	2	14
00 10 603	1, 1	6, 8
00 10 604	4	2
00 11 282	2	4
00 13 282	1	8
00 13 285	1	14
00 15 279	2	4
00 15 286	2	4
00 18 120	1	12
00 18 257	1	8
00 18 274	3, 1, 4	8, 12, 12
00 18 280	1, 3, 4	6, 6, 8
00 18 327	2	2
00 18 335	3, 3	4, 8
00 18 336	2, 4	4, 10
00 18 337	1, 1	4, 8
00 18 354	1	4
00 18 398	2, 2	8, 14
00 18 420	1	14
00 20 145	1, 1	2, 10
00 20 214	2, 2	6, 14
00 21 232	1, 1	2, 8
00 28 118	1	12
00 28 130	1	12
00 28 137	2	4
00 30 101	1	2
00 30 102	1	12
00 30 108	1	12
00 30 115	1	8
00 31 260	1	10
00 31 270	2, 2	2, 6
00 31 534	1, 1	2, 6
00 33 318 25	1	8
00 34 147	2	4
00 34 201	4, 4, 4, 1, 4, 1, 2	2, 2, 4, 4, 8, 8, 14
00 36 176	1	8
00 36 185	1	8
00 40 190	1, 1, 1	6, 8, 12
00 42 301	1	10
00 44 271	1, 1	6, 8
00 44 289	1	8
00 50 187	1	2
00 50 188	1, 1	2, 6
00 52 255	1	2
00 52 257	1, 1	2, 6

Bestell-Nr. Order-No. No. de Cde Ref.-Nr.	Menge Quantity Nombres Cantidad	Seite Page Page Pagina
00 54 251	1, 1	2, 6
00 54 252	1	2
00 55 101	1	14
00 55 104	1, 1	2, 6
00 55 136	1, 1	2, 6
00 55 267	2	2
00 61 356	1	12
00 62 147	1	8
00 62 246	1	4
00 62 256	1	6
00 63 186 25	1	10
00 64 292	110 mm	2
00 64 300	170 mm	8
00 64 300	170 mm	12
00 64 407	26 mm	4
00 64 407	26 mm	8
00 64 432	1, 1	4, 4
00 66 314	1	2
00 66 335	1	2
00 67 124	1	12
00 68 220	1	8
00 68 266	1	8
00 68 372	1	8
00 69 788	1, 1	6, 14
00 69 889	1	10
00 70 253	1, 1, 1	6, 8, 12
00 70 254	1	6
00 72 140	2	12
00 72 144	4	4
00 72 145	1, 1	2, 10
00 72 148	2, 1	2, 10
00 73 108	2, 2	4, 8
00 73 109	1, 1	8, 10
00 73 279	1, 1	8, 12
00 73 339	1	12
00 73 347	1	2
00 73 351	1	12
00 73 365	1	10
00 73 392	1	12
00 73 439	1	12
00 75 100	1	2
00 84 621	1	2
00 84 702	1	2
00 94 252	1	8
00 94 288	1	12
00 94 294	1, 1	4, 8
00 98 122	1, 1, 1	4, 8, 12
00 98 141	1	12
00 98 142	1	12
00 98 143	1, 1	8, 12
05 10 952	1	4

Bestell-Nr. Order-No. No. de Cde Ref.-Nr.	Menge Quantity Nombres Cantidad	Seite Page Page Pagina
05 40 203		14
05 40 204		14
05 40 205		14
05 40 249		14
05 40 250		14
05 40 251		14
20 11 868	1	2
20 31 249 25	1	2
20 36 381	1	12
20 42 726	1	6
20 48 404	1	2
20 61 436	1	4
20 61 442	1	4
20 61 443	1	4
20 61 473	1, 1	2, 8
20 61 524	1	2
20 63 333	1	2
20 74 209 25	1	10
20 74 408 25	1	10
20 74 419 25	1	10
20 74 429	1	12
20 74 469	1	4
20 74 946	1	4
21 00 659 44	1, 1, 1, 1	2, 6, 8, 10
22 00 345	1	2
22 00 654 52	1, 1	2, 6
23 00 469	1, 1	2, 8
23 00 730	1	2
23 00 752	1	2
23 00 842 01	1	4
23 00 858	1	4
24 00 289 25	1, 1	2, 10
25 00 502	1, 1	4, 10
25 00 604 25	1	4
25 00 641	1	4
25 00 820	1	4
26 00 283	1	10
26 00 327	1	10
26 00 335	1	10
27 00 135	1	12
27 00 322	1, 1	4, 8
27 00 326	1	8
27 00 353	1	12
27 00 354	1	12
27 00 382	1	8
27 00 414	1, 1	8, 12
28 00 285 25	1, 1	4, 12
35 00 362 25	1, 1	2, 6
35 00 405	1, 1	2, 6
60 11 728 25	1, 1	6, 14
60 32 639	1	12

Bestell-Nr. Order-No. No. de Cde Ref.-Nr.	Menge Quantity Nombres Cantidad	Seite Page Page Pagina
60 32 641	1	14
60 32 669	1	12
60 42 817	1, 1	2, 6
60 42 827	1, 1, 1	4, 8, 8
60 43 247	1	4
60 43 330	1, 1	8, 14
60 43 351	1	14
60 43 352	1	8
60 43 651	1	14
60 63 156	1, 1	4, 8
60 63 301	2	12
60 63 329	1, 1	6, 8
60 63 341	1	12
60 71 258	1	14
60 73 363	1, 1	4, 8
60 73 681 25	1	12
60 73 695	1	10
60 74 126	1	14
60 74 292	1	12
60 74 401	1, 1	4, 8
60 74 409	1	6
60 74 422	2	8
60 74 443	1	12
60 74 447	1, 1	6, 8
60 74 696	2, 2	6, 14
60 74 709	1	10
60 74 958	1, 1	4, 8
60 74 976	1, 1	2, 6
60 74 992	1, 1	4, 8
60 74 993	1, 1	4, 8
60 74 999	1	6
61 00 456	1	12
61 00 462	1	8
62 00 131 25	1	6
63 00 155	4	8
63 00 175 25	1, 1, 1	6, 8, 12
63 00 208 25	1	6
64 00 156	1	6
64 00 229	1, 1	6, 8
67 00 124	1, 1	6, 8
68 00 239	1	12
68 00 241 25	1	12
69 00 342		14
69 00 343		14
69 00 704		14
69 00 861		14
69 00 875		14
69 00 884		14

D
Allgemeine Richtlinien für die Bestellung von Original SOLO Ersatzteilen:
Voraussetzung für eine reibungslose Erledigung sind folgende Angaben:
1. Ersatzteil-Bestellnummer
2. Gewünschte Anzahl
3. Typenbezeichnung des Geräts
Diese Ersatzteilliste ist für die Lieferung und Ausstattung von SOLO Erzeugnissen unverbindlich. Im Interesse der technischen Weiterentwicklung bleiben Konstruktionsänderungen vorbehalten.

GB
General Directions for Ordering Original SOLO Spare Parts:
For correct and diligent processing of your order, please give the following information:
1. Spare Part number
2. Quantity
3. Model and serial number
4. Shipping instructions
Delivery is made in accordance with our general sales and delivery conditions. This spare parts list is non-committal for us with regard to delivery and layout of SOLO products. In favour of technical improvements, design modifications are subject to change without notice.

F
Directives générales pour les commandes de pièces de rechange d'origine SOLO:
Il est indispensable de préciser dans toutes les commandes de pièces:
1. le numéro de référence de la pièce
2. la quantité
3. le type de la machine
4. le mode d'expédition
Les livraisons sont effectuées dans le cadre de nos conditions générales de vente. Toutes modifications réservées.

E
Directivas Generales de pedido de la firma SOLO:
Por adelantado de un arreglo sin dificultades necesitamos siguientes indicaciones:
1. Número de repuesto
2. Numero de cantidad
3. Modelo y número de serial
4. Instrucción de Envío
Esta lista de repuestos no es obligatoria para los envíos y/o forma de equipo de los productos SOLO. En el interés del constante desarrollo debemos reservarnos el derecho de cambios.